

DAWSON®

DIR275

Infrared Thermometer Operations Manual

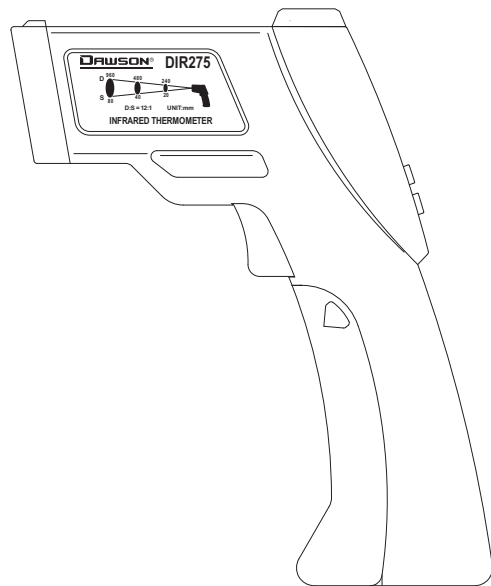

CE

CONTENTS

1. Safety Information	1
2. Warning	1
3. Buttons and Components.....	2
4. Display Description.....	3
5. IRT Technology.....	4
6. Operating Instructions	4
6.1 Preparation	4
6.2 Turning On The Instrument	4
6.3 Selecting Emissivity.....	4
6.4 Selecting Temperature Units.....	5
6.5 Surface Temperature Measurements	5
6.6 Thermal Bridge Mode	5
6.7 Mold Warning Mode.....	6

CONTENTS

7. Error Messages	8
7.1 Temperature Sensor Not Acclimated.....	8
7.2 Ambient Temperature Outside Operating Range.....	8
7.3 Surface Temperature Outside Measureable Range	9
7.4 Internal Error	10
8. Distance to Spot Ratio (D:S)	10
9. Emissivity	11
10. Thermal Bridge	12
11. Changing the Battery.....	12
12. Specifications.....	13

1. Safety Information

- Please read the following information carefully before using the meter.
- Do not clean the meter using solvents.
- Safety symbols:
 Important safety information.

 Complies with European CE safety standards. This instrument is compatible with the following standards:

- EN61326-1
- EN61010-1
- EN60825-1

WARNING

Do not point laser directly at eyes or indirectly off reflective surfaces.

2. Warnings

- When ambient temperature changes quickly, wait 30 minutes to balance the heat of the instrument before use.
- Avoid EMF (electromagnetic fields) from arc welds, induction furnaces, etc.
- Do not leave the unit on or near high temperature objects.
- Keep the instrument clean. Avoid dust getting on the sensor to maintain the accuracy of the thermometer.

3. Buttons and Components

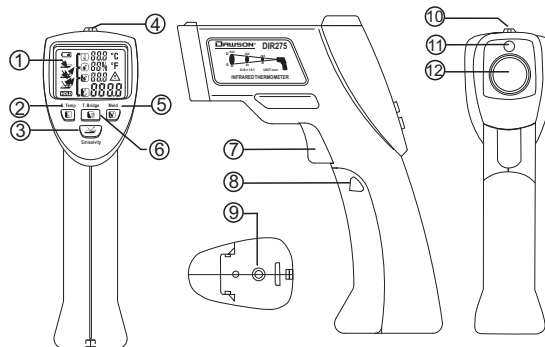

1. LCD
2. Surface temp. button
3. Emissivity button
4. Temp/humidity sensor
5. Mold mode button
6. Thermal bridge button
7. Trigger
8. Battery cover
9. Tripod mounting hole
10. Aiming sight
11. Laser pointers
12. Infrared sensor

4. Display Description

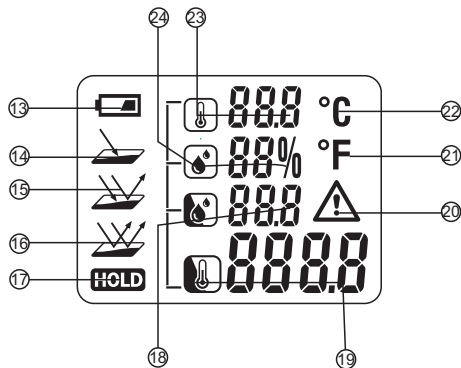

- 13. Low battery indicator
- 14. High emissivity
- 15. Medium emissivity
- 16. Low emissivity
- 17. Hold readings
- 18. Dew point temperature
- 19. Surface temperature
- 20. Warning symbol
- 21. Degrees Fahrenheit
- 22. Degrees Celsius
- 23. Ambient temperature
- 24. Relative humidity

5. IRT Technology

An infrared thermometer detects the infrared radiation that an object emits. The sensor determines how much infrared radiation the object is giving off and the internal microprocessor converts that reading into a temperature reading. Using this method the thermometer can measure an object's temperature without touching the object. The lasers are only used to aim the thermometer at the target.

6. Operating Instructions

6.1 Preparation

1. Do not subject the instrument to extreme temperature variations. This can impair the accuracy of the instrument.
2. Avoid heavy impacts/dropping the instrument.
3. Avoid covering the temp/humidity sensor, infrared sensor, or the laser pointers.

6.2 Turning On The Instrument

To turn on the instrument, press either the trigger or any of the face buttons. The meter will start up with the last settings that were used.

6.3 Selecting Emissivity

To correctly determine the surface temperature of an object, you need to set the emissivity accordingly. The instrument has 3 emissivity setting:

High Emissivity (0.95)

Concrete (dry), bricks (red, course), sandstone (course), marble, roofing felt, stucco (course), mortar, gypsum, parquet flooring (matte), flooring panels, PVC, carpet, wallpaper (patterned), tiles (matte), glass, aluminum (anodized), enamel, wood, rubber, ice

Medium Emissivity (0.85)

Granite, paving stone, fiberboard, wallpaper (lightly patterned), varnish (dark), metal (matte), ceramic, leather.

Low Emissivity (0.75)

Porcelain (white), varnish (light), cork, cotton

To change the emissivity setting, press the  button until the display shows the correct emissivity degree desired.

6.4 Selecting Temperature Units

To switch between Celsius and Fahrenheit, hold the  button down.

6.5 Surface Temperature Measurements

1. To measure the temperature of an object, press the button  to enter surface temperature mode.

Note: Highly reflective or transparent surfaces can affect surface temperature measurements. If necessary, cover area with matte tape and allow tape to acclimate to the surface temperature before measuring.

6.6 Thermal Bridge Mode

Thermal bridge mode compares the surface temperature with the ambient temperature. If the temperature difference is large enough, the LED above the display will change from green to either yellow or red to indicate the possible presence of a thermal bridge.

1. To active thermal bridge mode, press the  button to enter thermal bridge mode.
2. Point the instrument at the object and hold down the trigger. The laser pointers will activate showing the area in which the infrared sensor can see.

3. The display will show the current surface temperature of the object within the measurement spot along with the ambient temperature. After releasing the trigger the display will hold the current measurement.

4. The LED above the display will indicate the possible presence of a thermal bridge.

- Green: Low temperature difference. No thermal bridge detected.
- Yellow: Medium temperature difference. Possible thermal bridge present. Check again at a later time to verify.
- Red: High temperature difference. Thermal bridge detected. The display will flash the surface temperature icon

5. After approx. 25s from releasing the trigger, the instrument will automatically turn itself off.

Note: Check the insulation if a thermal bridge is detected.

6.7 Mold Warning Mode

Mold warning mode compares the surface temperature with the dew point temperature. Dew point temperature is calculated using the ambient temperature and the relative humidity. If the temperature difference is small enough, the LED above the display will change from green to either yellow or red to indicate the possible presence of mold.

1. To activate mold warning mode, press the  button to enter mold warning mode.
2. Point the instrument at the object and hold down the trigger. The laser pointers will activate showing the area in which the infrared sensor can see.

3. The display will show the current surface temperature of the object within the measurement spot, ambient temperature, relative humidity and dew point temperature. After releasing the trigger the display will hold the current measurement.

4. The LED above the display will indicate the possible presence of mold.

- Green: High temperature difference. No risk of mold detected.
- Yellow: Medium temperature difference. Possible mold risk present. Check again at a later time to verify.
- Red: Low temperature difference. High risk of mold detected. The display will flash the appropriate measurement that may be the cause.

5. After approx. 25s from releasing the trigger, the instrument will automatically turn itself off.

Note: Reduce the humidity or increase the ambient temperature if high risk of mold is detected. The instrument **cannot** detect mold spores. The instrument only gives an indication that mold formation is possible at the given location.

7. Error Messages

7.1 Temperature Sensor Not Acclimated

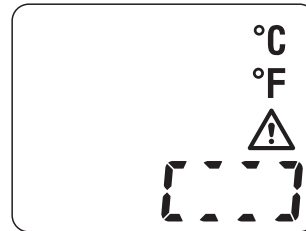

1. The instrument has been exposed to severe temperature variations and needs time to acclimatize to the current environment.
2. The instrument will show the above symbols.
3. Keep the instrument in the current environment for approx. 10-30 minutes so it has enough time to adapt to the environment.

7.2 Ambient Temperature Outside Operating Range

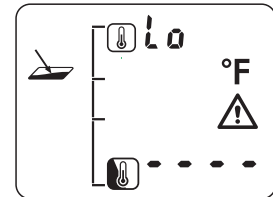
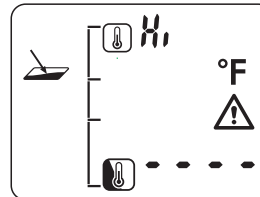

1. The ambient temperature is either too high or too low for operation.
2. The instrument will show the above symbols.
3. Taking measurement in the current environment is not possible.

7.3 Surface Temperature outside Measureable Range

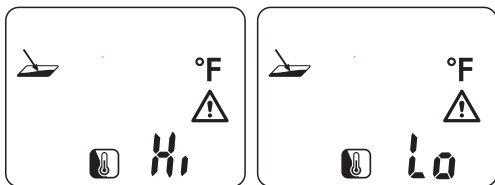

1. The surface temperature of the object within the measurement spot is either too high or too low for measurement.
2. The instrument will show the above symbols.
3. Temperature of this object cannot be measured.

7.4 Internal Error

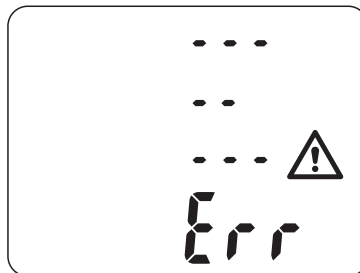

1. The instrument has encountered an internal error.
2. The instrument will show the above symbols.
3. To reset, remove the battery, wait a few seconds, then re-insert battery.

Note: If the problem persists, the instrument may need to be taken in for service.

8. Distance to Spot Ratio (D:S)

The thermometer has a visual angle and visual spot size; the following drawing illustrates this:

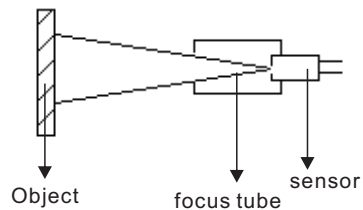

Make sure that the target is larger than the unit's visual spot size; the smaller the target, the closer the thermometer should be to it. The ratio between distance and spot size is 12:1; the following drawing illustrates this:

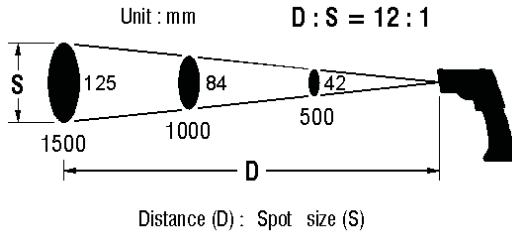

To prevent the sensor from picking up IR radiation from additional sources, make sure the thermometer is closer to the target object than the D:S ratio.

9. Emissivity

Emissivity is a term used to describe the energy emitting characteristics of a material. The greater the emissivity, the more energy the object is capable of emitting. Most organic materials and oxidized metal surfaces have an emissivity between 0.85 to 0.98. The thermometer's sensor has the ability to be adjusted to 3 different emissivity settings: high (0.95), medium (0.85) and low (0.75).

10. Thermal Bridge

A thermal bridge is any object that allows the transfer of heat or energy from one side to another. Because the surface temperature of an object at a thermal bridge is lower than the rest of the room, the risk of mold increases significantly at these locations.

11. Changing the battery

When the battery symbol appears on the display, it indicates that the battery needs to be changed. Press the casing at the OPEN symbols on both sides of the battery cover and pull it away from the meter to open the cover. See the drawing below:

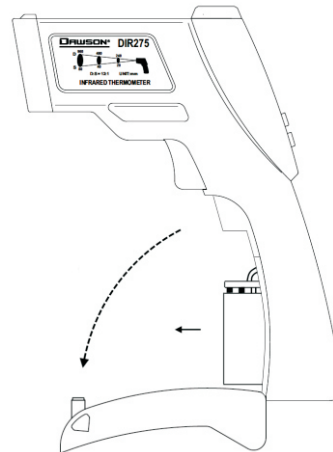

12. Specifications

LCD display:	4 line digital display
D:S:	12:1
Spectral Response:	8-14 μm
Measurement range:	
Surface Temp:	-20~350°C (-4 ~662°F)
Ambient Temp.:	-10~40°C (14~104°F)
Relative Humidity:	10~90%
Accuracy:	
Surface Temp:	<10°C $\pm 3^{\circ}\text{C}$ 10~30°C $\pm 1^{\circ}\text{C}$ >30°C $\pm 1.5\% + 2^{\circ}\text{C}$
Ambient Temp.:	-10~40°C $\pm 1^{\circ}\text{C}$
Relative Humidity:	<20% $\pm 4\%$ 20~80% $\pm 3\%$ >80% $\pm 4\%$
Operating Temp.:	-10~40°C
Storage Temp.:	-20~60°C
Laser Class:	2
Laser Type:	650nm<1 mw
Battery Type:	9V
Low Battery Indication:	<80%
Emissivity:	0.75, 0.85, 0.95
Response time:	0.5 seconds
Automatic Power Off:	25s
Size:	194x56x162 mm
Weight:	approximately 280g (w/battery)
Accessories:	9V battery Operations Manual Pouch

